

# FLS F3.00.W

## WIRELESS PADDLEWHEEL FLOW SENSOR

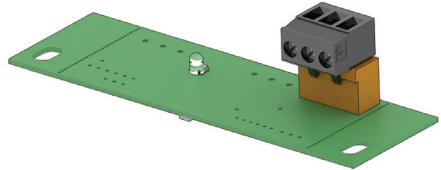

## SAFETY INSTRUCTIONS

### General Statements

- Do not install and service the product without following the Instruction Manual.
- This item is designed to be connected to other instruments which can be hazardous if used improperly. Read and follow all associated instrument manuals before using with it.
- Product installation and wiring connections should only be performed by qualified staff.
- Do not modify product construction.
- To optimize the system functionality, please refer to section “System location”.

### Installation and Commissioning Statements

- Remove power to the instrument before wiring input and output connections.
- Do not exceed maximum specifications using the instrument.
- To clean the unit, use only chemical compatible products.

# WASTE OF ELECTRIC AND ELECTRONIC EQUIPMENT

This product falls under the field of application of Directive 2012/19/EU concerning electric and electronic equipment waste management (WEEE).

The equipment must not be discarded with domestic waste since made up of various materials that can be recycled at suitable centres. Apply to your town authorities as to the location of disposal sites that can receive the product for disposal and subsequent correct recycling.

Please also remember that the distributor is required to freely dispose of old products when an equivalent product is purchased.

The product is not potentially harmful to human health and the environment since it does not contain harmful substances as per Directive 2011/65/EU (RoHS) but can negatively impact the environment if littered.

Carefully read the instructions before using the equipment for the first time. Please do not use the product in any way other than its intended use since this could cause electrical shock.



The barred bin on the equipment label indicates product compliance with electric and electronic equipment waste regulations.

Littering the environment with this equipment or incorrect disposal are punishable by law.

## PACKING LIST

Please verify that the product is complete and without any damage.

The following items must be included:

- F3.00.W Bluetooth® system: paddlewheel with integrated transmitter, PCB receiver, DIN bar case adapter, PCB receiver spacers for wall mounting box installation
- Instruction Manual for F3.00.W Bluetooth® system

## DESCRIPTION

The new FLS Wireless Paddlewheel Flow Sensor F3.00.W is an innovative system for flow monitoring based on Bluetooth® transmission technology. The paddlewheel flow sensor is provided with an integrated transmitter that communicates with the receiver. The receiver is compatible with FLS monitors (from release 5.0.1.) or other devices which can provide digital inputs. For former releases please update the item downloading the latest software release on [flsnet.it](http://flsnet.it).

The FLS F3.00.W is a reliable solution for every kind of solid-free liquid. Easy and quick to install, it is suitable for pipes in different materials, sized from DN15 to DN600 (0.5" to 24").

It can cover also long operating distances up to 100 meters and work in presence of electromagnetic interferences generated by devices like pumps and inverters. Besides thanks to the auto-diagnostic system, the user is always informed about the lack of signal and the exhausted battery.

## TECHNICAL DATA

### General

- Pipe Size Range: DN15 to DN600 (0.5" to 24")
- Please refer to Installation Fittings section on FLS catalogue for more details
- Flow Rate Range: 0.15 to 8 m/s (0.5 to 25 ft/s)
- Linearity:  $\pm 0.75$  % of full scale
- Repeatability:  $\pm 0.5$  % of full scale
- Minimum Reynolds Number Required: 4500
- Enclosure: IP65
- Wetted Materials:
  - sensor Body: CPVC, PVDF, 316L SS
  - o-rings: EPDM or FPM
  - rotor: ECTFE (Halar®)
  - shaft: Ceramic ( $Al_2O_3$ ) / 316L SS (only for metal sensors)
  - bearings: Ceramic ( $Al_2O_3$ )

### Electrical

- Transmitter:
  - Power Supply: 3.6 volt Lithium Thionylchloride Battery, size C, 8.5 AHR
  - Battery life: nominal 2 years
- Receiver:
  - Power Supply: 5-24 VDC  $\pm 10\%$ @20mA
  - Output signal for flow and for signal lack:
    - square wave
    - frequency: 45Hz per m/s nominal (13,7 Hz per ft/s nominal)
    - type: transistor NPN open collector
  - Output signal for low battery:
    - type: NPN open collector
    - max pull-up voltage: 24V DC
    - max current: 50mA
    - battery level: 0VCC low battery +VCC fully charged

### Environmental

- Operating temperature: -20 to +70°C (-4 to 158°F)
- Storage temperature: -30 to +80°C (-22 to 176°F)
- Relative humidity: 0 to 95% not condensing

### Standards & Approvals

- Manufactured under ISO 9001
- Manufactured under ISO 14001
- CE
- RoHS Compliant
- GOST R

## Maximum Operating Pressure / Temperature (25 years lifetime)

- CPVC body:
  - 10 bar (145 psi) @ 25°C (77°F)
  - 1,5 bar (22 psi) @ 80° C (176°F)
- PVDF body:
  - 10 bar (145 psi) @ 25°C (77°F)
  - 2,5 bar (36 psi) @ 100°C (212°F)
- SS body:
  - 25 bar (363 psi) @ 100°C (212°F)

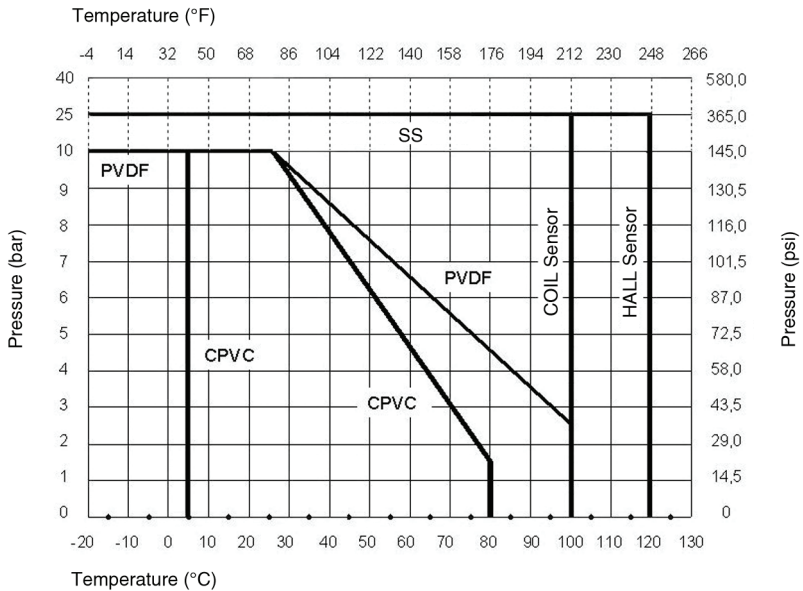

# DIMENSIONS

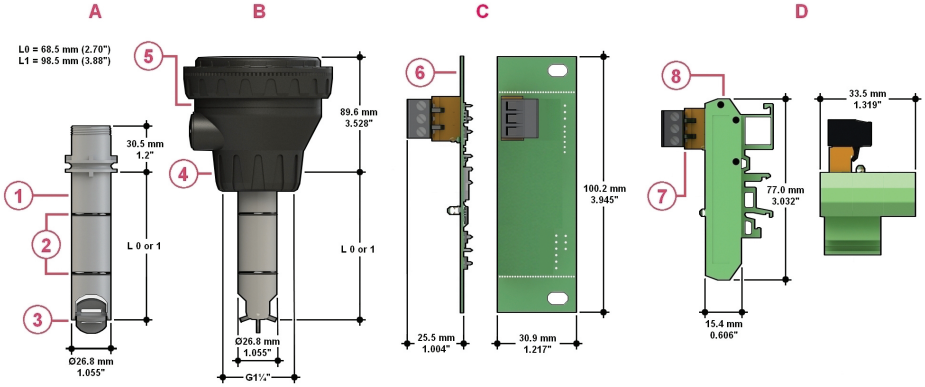

**A** Sensor body

**B** F3.00.W Paddlewheel Flow transmitter

**C** Receiver PCB

**D** Receiver + DIN bar adapter

**1** Sensor body PVCC, PVDF, 316L SS

**2** O-Ring (EPDM or FPM)

**3** Halar Rotor, Ceramic shaft & bearings for PVDF and PVC-C version and 316 SS shaft for metal version

**4** ABS cap for installation into fittings

**5** Electronic box

**6** PCB

**7** Connectors

**8** DIN bar case adapter

# INSTALLATION

## System Location

- Nominal distance: 100m (maximum, open field)
- Operating distance is reduced by following elements:

- tank with liquid
- concrete walls
- fire doors
- metal doors
- metal panels

- Optimal installation conditions:

- indoor ambient
- the receiver must face the transmitter. To identify the proper position please refer to the FIP mark on the box cap. Receiver must face the left side of FIP mark (see the image below)

**NO**

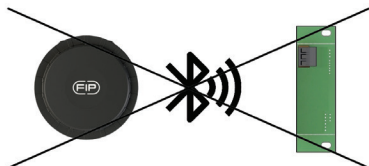

**OK**



- To verify the correct F3.00.W system location, use the following procedures:
- Insert a charged battery into the trasmitter.

- To connect with FLS monitor:

- Follow the first calibration procedure on the monitor.
- Select the option wireless sensor F3.00.W.
- Check the signal strength with the specific function “SIGNAL INTENSITY” in the calibration menu. The system will return one of the following intensity level:

**LOW** > the level of signal is low; any possible external factor can easily degrade it. It is recommended to reconsider the system location.

**MEDIUM** > the level of signal is adequate; it is recommended to avoid upsetting the installation condition (e.g. avoid adding structural elements as concrete walls between transmitter and receiver)

**HIGH** > the level of signal is good and safe.

- To connect with PLC:

- Check the signal strength:

> Put the JUMPER in the “SIGNAL TEST” position as indicated in the image below.

> Connect with digital input, as indicated in the section “POWER WIRING DIAGRAM”.

> Set the PLC considering the following correspondence between the output frequency and the signal intensity:

**100Hz** > the level of signal is low; any possible external factor can easily degrade it.

It is recommended to reconsider the system location

**200Hz** > the level of signal is adequate; it is recommended to avoid upsetting the installation condition (e.g. avoid adding structural elements as concrete walls between transmitter and receiver)

**300Hz** > the level of signal is good and safe.

- Make sure to put the JUMPER in the position “PARK” to make the system operative. Please refer to image below.

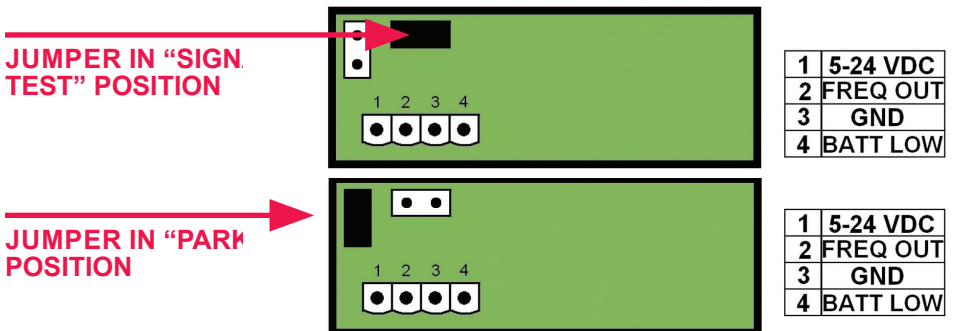

## Pipe Location

- The six most common installation configurations shown in fig. 1 help in selecting the best location in the pipeline for paddlewheel flow sensor as well for magmeter flow sensor.
- The three configurations in fig. 2 ensure that the pipe is always full: for a correct measurement the sensor can NOT be exposed to air bubbles at any time.
- The three installations in Fig. 3 should be avoided unless you are absolutely sure the sensor is not exposed to air bubbles.
- In gravity-flow systems the connection to the tank must be designed so the level does not drop below the outlet: this to avoid pipe to draw air in from the tank causing an inaccurate measurement of sensor (see Fig. 4).
- For more information, please refer to EN ISO 5167-1.
- Always maximize distance between flow sensors and pumps.

Fig.1

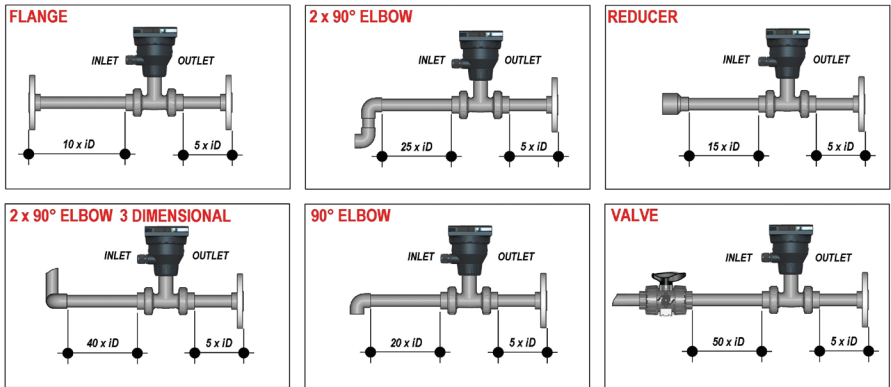

Fig.2

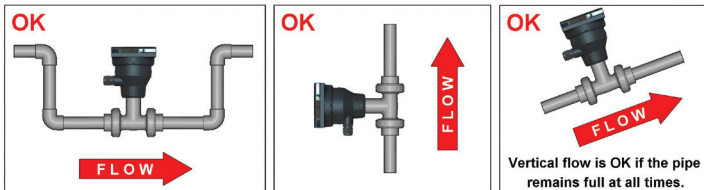

Fig.3

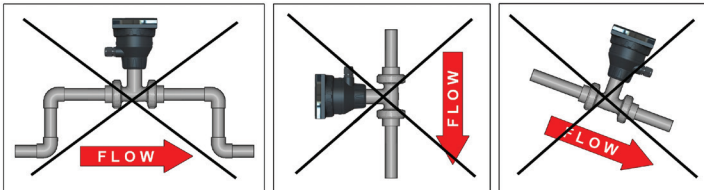
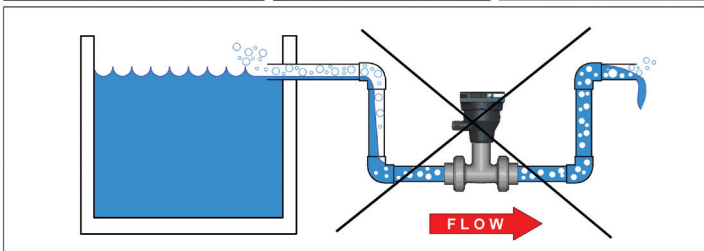

Fig.4



## Mounting position

Measuring part of sensor (rotor for paddlewheel and pins for magmeter) should be positioned at 12% of ID where, basing on insertion theory, average velocity can be measured.

The reading accuracy of insertion flow sensors can be affected by:

- air bubbles;
- sediments;
- friction between shaft and bearings.

In a horizontal pipe runs, the mounting position to get the best performances is at a 45° angle (Fig. 3) to avoid air bubbles as well sediments. Vertical position (Fig. 2) can be chosen in case air bubbles are not present. Do not mount the sensor on the bottom of the pipe (Fig. 1) if sediments are likely. Do not mount paddlewheel at 90° otherwise friction can affect measurement.

Installation in a vertical pipe runs can be done fixing any orientation. Upward flow is preferred to ensure full pipe.

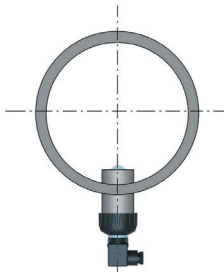

Fig. 1

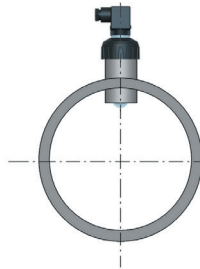

Fig. 2

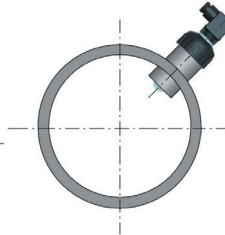
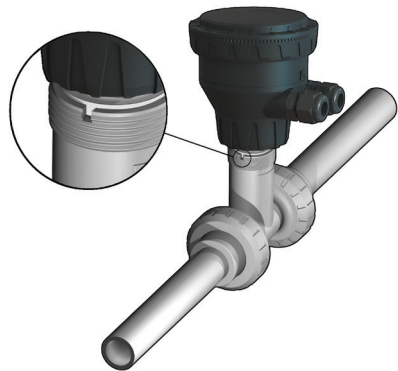

Fig. 3

## Process connection

1. Lubricate the sensor O-rings with a silicone lubricant. Do not use any petroleum based lubricant that may damage the O-rings.
2. Lower the sensor into the fitting making sure the alignment tab is seated in the fitting notch.
3. Hand tighten the sensor cap. Do not use any tool otherwise cap and/or fitting threads may be damaged.





## Receiver installation

### Wall mounting W1-W2

1. Clean the surface where the PCB must be glued
3. Remove the protective film from the PCB support already mounted
4. Install the PCB according to the picture. Installation on the upper part of the box is recommended.

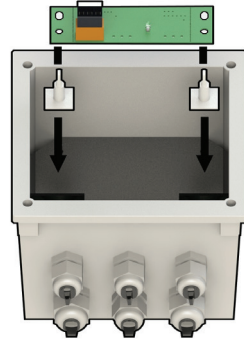

### DIN bar adapter

1. Remove the external fins following the dotted line indication on the receiver PCB see figure 1
2. assemble the receiver PCB following the sequence in the figure 2

REMOVABLE PART

REMOVABLE PART

Fig.1

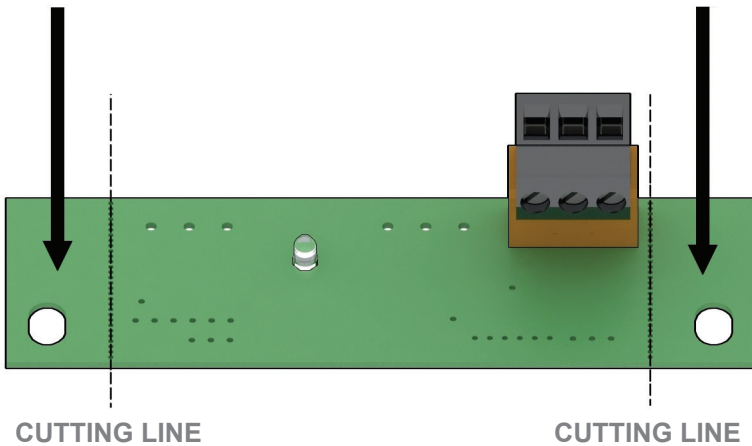
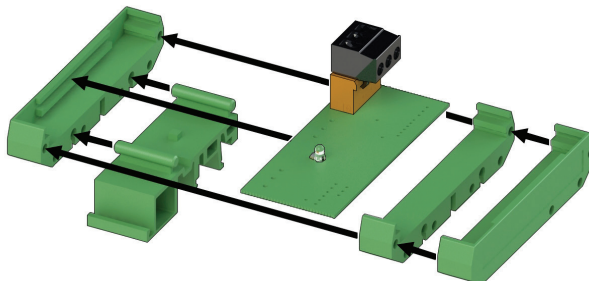

Fig.2



# WIRING



## General recommendation

Always ensure the power supply is switched off before working on the device. Make wiring connections according to wiring diagrams.

- Terminals accept 26 to 12 AWG (0.08 to 2.5 mm<sup>2</sup>)
- Strip around 10 mm (0.4") of insulation from the wire tips and tin bare ends to avoid fraying.
- Ferrules are suggested when connecting more than one wire to a single terminal.
- Remove the upper part of the terminals for an easy cabling.
- Insert wire tip or ferrule completely into the terminal and fix with the screw until finger tight.
- Do not route the sensor or DC power in conduit containing AC power wiring. Electrical noise may interfere with sensor signal.
- Routing the sensor cable in grounded metal conduit can help prevent electrical noise and mechanical damage.
- Seal the cable entry points to prevent moisture damage.

## REAR TERMINAL VIEW

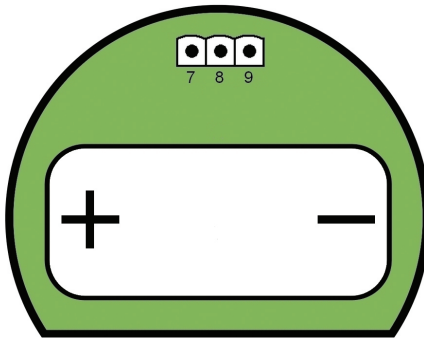

Transmitter

7	GND
8	FREQ IN
9	+V

Flow Sensor

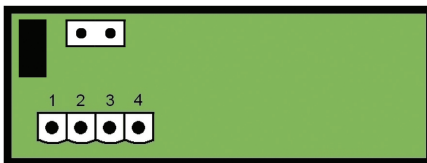

Receiver

1	5-24 VDC
2	FREQ OUT
3	GND
4	BATT LOW

# POWER WIRING DIAGRAM

Connection to  
FLS M9.02 monitor

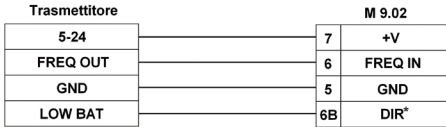

Connection to FLS M9.03, M9.07  
and M9.08 monitors

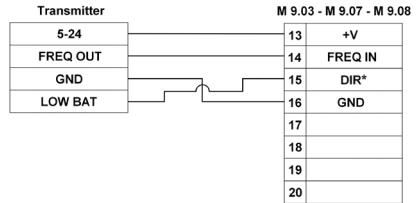

Connection to  
FLS M9.03 monitor sensor input 1

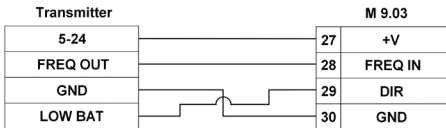

Please note: on M9.02, M9.03, M9.07 and M9.08 DIR is the connection for low battery alarm.

## Connection to a PLC

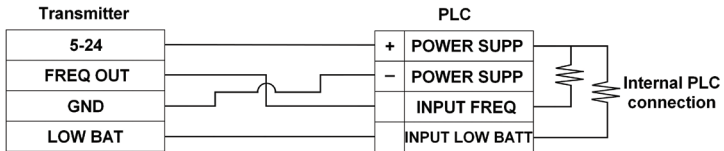

## Connection for signal intensity function

**JUMPER IN  
"SIGNAL TEST"  
POSITION**

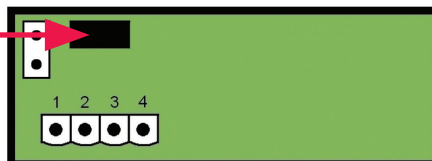

1	5-24 VDC
2	FREQ OUT
3	GND
4	BATT LOW

# INSTALLATION FITTINGS

	Type	Description
	Plastic Tees	<ul style="list-style-type: none"> <li>• Size: d20 to d50 (0.5" to 1.5")</li> <li>• Materials: PVC, C-PVC, PP, PVDF</li> </ul>
	PVC-U Clamp Saddles	<ul style="list-style-type: none"> <li>• Size: d63 to d225 (2" to 8")</li> <li>• Insert Materials: C-PVC, PVDF</li> </ul>
	316L SS Tees	<ul style="list-style-type: none"> <li>• Size: d63 to d315</li> <li>• Materials: PVC, C-PVC, PP, PE</li> </ul>
	Metal Strap-on Saddles	<ul style="list-style-type: none"> <li>• Size: DN80 to DN450</li> <li>• Insert Material: C-PVC</li> <li>• Special order for other sizes</li> </ul>
	316L SS Weld-on Adapters	<ul style="list-style-type: none"> <li>• Size: d50 to d600 (1.5" to 24")</li> </ul>

# K-FACTOR TABLES

K-Factor is the number of pulses which a sensor produces for one liter of measured fluid. Here below all K-Factors for water at room temperature are listed.

K-Factor values can depend on the installation conditions. K-Factor has to divide the frequency generated by F3.00 in order to achieve the flow rate (l/s). Please contact your dealer for K-Factor values not included in the table.

## Installation on PVC pipes

ISO Metric PVC Tee Fittings for ISO SDR 21 pipes (female ends for solvent welding)			
Part No.	DN	d	K-Factor
TFIV20B	15	20	235,45
TFIV25B	20	25	142,46
TFIV32B	25	32	91,53
TFIV40B	32	40	51,57
TFIV50B	40	50	42,89
TFIV20D	15	20	235,45
TFIV25D	20	25	142,46
TFIV32D	25	32	91,53
TFIV40D	32	40	51,57
TFIV50D	40	50	42,89

ISO Metric Clamp Saddles for ISO SDR 21 pipes (PN10 up to d 90mm, PN12,5 from d 110mm)			
Part No.	DN	d	K-Factor
SVIC063BVC	50	63	21,69
SVIC075BVC	65	75	14,98
SVIC090BVC	80	90	9,88
SVIC110BVC	100	110	6,06
SVIC125BVC	110	125	4,59
SVIC140BVC	125	140	3,59
SVIC160BVC	150	160	2,69
SVIC200BVC	180	200	1,65
SVIC225BVC	200	225	1,28
SVIC063DVC	50	63	21,69
SVIC075DVC	65	75	14,98
SVIC090DVC	80	90	9,88
SVIC110DVC	100	110	6,06
SVIC125DVC	110	125	4,59
SVIC140DVC	125	140	3,59
SVIC160DVC	150	160	2,69
SVIC200DVC	180	200	1,65
SVIC225DVC	200	225	1,28
SMIC250IVC	225	250	1,01
SMIC280IVC	250	280	0,79
SMIC315IVC	280*	315	0,61

BSP Female Threaded PVC Tee Fittings for BS PN12 pipes (parallel threaded female ends)			
Part No.	DN	R	K-Factor
TFFV20B	15	1/2"	235,45
TFFV25B	20	3/4"	142,46
TFFV32B	25	1"	91,53
TFFV40B	32	1" 1/4	51,57
TFFV50B	40	1" 1/2	42,89
TFFV20D	15	1/2"	235,45
TFFV25D	20	3/4"	142,46
TFFV32D	25	1"	91,53
TFFV40D	32	1" 1/4	51,57
TFFV50D	40	1" 1/2	42,89

BS Solvent Welding PVC Tee Fittings for BS PN12 pipes (female ends for solvent welding)			
Part No.	DN	d	K-Factor
TFLV20B	15	1/2"	235,45
TFLV25B	20	3/4"	142,46
TFLV32B	25	1"	91,53
TFLV40B	32	1" 1/4	51,57
TFLV50B	40	1" 1/2	42,89
TFLV20D	15	1/2"	235,45
TFLV25D	20	3/4"	142,46
TFLV32D	25	1"	91,53
TFLV40D	32	1" 1/4	51,57
TFLV50D	40	1" 1/2	42,89

**NPT Female Threaded PVC Tee Fittings  
for ASTM SCH. 80 pipes  
(NPT threaded female ends)**

Part No.	SIZE	R	K-Factor
TFNV20B	0.50"	1/2"	235,45
TFNV25B	0.75"	3/4"	142,46
TFNV32B	1.00"	1"	91,53
TFNV40B	1.25"	1" 1/4	51,57
TFNV50B	1.50"	1" 1/2	42,89
TFNV20D	0.50"	1/2"	235,45
TFNV25D	0.75"	3/4"	142,46
TFNV32D	1.00"	1"	91,53
TFNV40D	1.25"	1" 1/4	51,57
TFNV50D	1.50"	1" 1/2	42,89

**ASTM SCH. 80 PVC Tee Fittings  
for ASTM SCH. 80 pipes  
(female ends for solvent welding)**

Part No.	SIZE	d	K-Factor
TFAV20B	0.50"	1/2"	235,45
TFAV25B	0.75"	3/4"	142,46
TFAV32B	1.00"	1"	91,53
TFAV40B	1.25"	1" 1/4	51,57
TFAV50B	1.50"	1" 1/2	42,89
TFAV20D	0.50"	1/2"	235,45
TFAV25D	0.75"	3/4"	142,46
TFAV32D	1.00"	1"	91,53
TFAV40D	1.25"	1" 1/4	51,57
TFAV50D	1.50"	1" 1/2	42,89

**BS Clamp Saddles for BS PN12 pipes**

Part No.	DN	d	K-Factor
SVLC2.0BVM	50	2"	24,10
SVLC3.0BVM	80	3"	10,29
SVLC4.0BVM	100	4"	5,72
SVLC6.0BVM	150	6"	2,48
SVLC8.0BVM	200	8"	1,34
SVLC2.0DVM	50	2"	24,10
SVLC3.0DVM	80	3"	10,29
SVLC4.0DVM	100	4"	5,72
SVLC6.0DVM	150	6"	2,48
SVLC8.0DVM	200	8"	1,34

**ASTM SCH. 80 Clamp Saddles  
for ASTM SCH. 80 pipes**

Part No.	SIZE	d	K-Factor
SVAC2.0BVM	2.00"	-	29,74
SVAC2.5BVM	2.50"	-	20,25
SVAC3.0BVM	3.00"	-	12,36
SVAC4.0BVM	4.00"	-	6,47
SVAC5.0BVM	5.00"	-	4,00
SVAC6.0BVM	6.00"	-	2,68
SVAC8.0BVM	8.00"	-	1,46
SVAC2.0DVM	2.00"	-	29,74
SVAC2.5DVM	2.50"	-	20,25
SVAC3.0DVM	3.00"	-	12,36
SVAC4.0DVM	4.00"	-	6,47
SVAC5.0DVM	5.00"	-	4,00
SVAC6.0DVM	6.00"	-	2,68
SVAC8.0DVM	8.00"	-	1,46

## Installation on C-PVC pipes

ISO Metric CPVC Tee Fittings for ISO SDR 21 pipes (female ends for solvent welding)			
Part No.	DN	d	K-Factor
TFIC20B	15	20	235,45
TFIC25B	20	25	142,46
TFIC32B	25	32	91,53
TFIC40B	32	40	51,57
TFIC50B	40	50	42,89
TFIC20D	15	20	235,45
TFIC25D	20	25	142,46
TFIC32D	25	32	91,53
TFIC40D	32	40	51,57
TFIC50D	40	50	42,89

ISO Clamp Saddles for ISO SDR 21 pipes			
Part No.	DN	d	K-Factor
SVIC063BVC	50	63	21,69
SVIC075BVC	65	75	14,98
SVIC090BVC	80	90	9,88
SVIC110BVC	100	110	6,06
SVIC125BVC	110	125	4,59
SVIC140BVC	125	140	3,59
SVIC160BVC	150	160	2,69
SVIC200BVC	180	200	1,65
SVIC225BVC	200	225	1,28
SVIC063DVC	50	63	21,69
SVIC075DVC	65	75	14,98
SVIC090DVC	80	90	9,88
SVIC110DVC	100	110	6,06
SVIC125DVC	110	125	4,59
SVIC140DVC	125	140	3,59
SVIC160DVC	150	160	2,69
SVIC200DVC	180	200	1,65
SVIC225DVC	200	225	1,28
SMIC250IVC	225	250	1,01
SMIC280IVC	250	280	0,79
SMIC315IVC	280	315	0,61

## Installation on PP pipes

ISO Metric PP Tee Fittings for ISO SDR 11 pipes (female ends for socket welding)			
Part No.	DN	d	K-Factor
TFIM20B	15	20	212,17
TFIM25B	20	25	135,32
TFIM32B	25	32	89,36
TFIM40B	32	40	48,94
TFIM50B	40	50	42,10
TFIM20D	15	20	212,17
TFIM25D	20	25	135,32
TFIM32D	25	32	89,36
TFIM40D	32	40	48,94
TFIM50D	40	50	42,10

BSP Female Threaded PP Tee Fittings for BS pipes (parallel threaded female ends)			
Part No.	DN	R	K-Factor
TFFM20B	15	1/2"	212,17
TFFM25B	20	3/4"	135,32
TFFM32B	25	1"	89,36
TFFM40B	32	1" 1/4	48,94
TFFM50B	40	1" 1/2	42,10
TFFM20D	15	1/2"	212,17
TFFM25D	20	3/4"	135,32
TFFM32D	25	1"	89,36
TFFM40D	32	1" 1/4	48,94
TFFM50D	40	1" 1/2	42,10

ISO Clamp Saddles for ISO SDR 21 pipes

Part No.	DN	d	K-Factor
SVIC063BME	50	63	27,50
SVIC075BME	65	75	18,56
SVIC090BME	80	90	12,44
SVIC110BME	100	110	7,59
SVIC125BME	110	125	5,77
SVIC140BME	125	140	4,49
SVIC160BME	150	160	3,38
SVIC200BME	180	200	2,07
SVIC225BME	200	225	1,60
SVIC063DME	50	63	27,50
SVIC075DME	65	75	18,56
SVIC090DME	80	90	12,44
SVIC110DME	100	110	7,59
SVIC125DME	110	125	5,77
SVIC140DME	125	140	4,49
SVIC160DME	150	160	3,38
SVIC200DME	180	200	2,07
SVIC225DME	200	225	1,60
SMIC250IME	225	250	1,27
SMIC280IME	250	280	0,99
SMIC315IME	280	315	0,77

NPT Female Threaded PP Tee Fittings  
for ASTM SCH.80 pipes  
(NPT threaded female ends)

Part No.	DN	d	K-Factor
TFNM20B	0.50"	1/2"	212,17
TFNM25B	0.75"	3/4"	135,32
TFNM32B	1.00"	1"	89,36
TFNM40B	1.25"	1" 1/4	48,94
TFNM50B	1.50"	1" 1/2	42,10
TFNM20D	0.50"	1/2"	212,17
TFNM25D	0.75"	3/4"	135,32
TFNM32D	1.00"	1"	89,36
TFNM40D	1.25"	1" 1/4	48,94
TFNM50D	1.50"	1" 1/2	42,10

ASTM SCH. 80 Clamp Saddles  
for ASTM SCH. 80 pipes

Part No.	SIZE	d	K-Factor
SVAC2.0BME	2.00"	-	29,83
SVAC2.5BME	2.50"	-	20,37
SVAC3.0BME	3.00"	-	12,36
SVAC4.0BME	4.00"	-	6,47
SVAC5.0BME	5.00"	-	3,92
SVAC6.0BME	6.00"	-	1,53
SVAC8.0BME	8.00"	-	1,44
SVAC2.0DME	2.00"	-	29,83
SVAC2.5DME	2.50"	-	20,37
SVAC3.0DME	3.00"	-	12,36
SVAC4.0DME	4.00"	-	6,47
SVAC5.0DME	5.00"	-	3,92
SVAC6.0DME	6.00"	-	1,53
SVAC8.0DME	8.00"	-	1,44



## Installation on PVDF pipes

ISO Metric PVDF Tee Fittings for ISO SDR 33 pipes (female ends for socket welding)			
Part No.	DN	d	K-Factor
TFIF20B	15	20	225,06
TFIF25B	20	25	139,38
TFIF32B	25	32	94,66
TFIF40B	32	40	51,37
TFIF50B	40	50	43,07
TFIF20D	15	20	225,06
TFIF25D	20	25	139,38
TFIF32D	25	32	94,66
TFIF40D	32	40	51,37
TFIF50D	40	50	43,07

ISO Clamp Saddles for ISO SDR 33 pipes			
Part No.	DN	d	K-Factor
SVIF063BF	50	63	20,58
SVIF 075BF	65	75	14,09
SVIF 090BF	80	90	9,29
SVIF 110BF	100	110	5,69
SVIF 125BF	110	125	4,31
SVIF 140BF	125	140	3,36
SVIF 160BF	150	160	2,52
SVIF 200BF	180	200	1,55
SVIF 225BF	200	225	1,20
SVIF 063DF	50	63	20,58
SVIF 075DF	65	75	14,09
SVIF 090DF	80	90	9,29
SVIF 110DF	100	110	5,69
SVIF 125DF	110	125	4,31
SVIF 140DF	125	140	3,36
SVIF 160DF	150	160	2,52
SVIF 200DF	180	200	1,55
SVIF 225DF	200	225	1,20

## Installation on PE pipes

ISO Metric PVC Tee Fittings for PE SDR 11 pipes (PE end connectors for electrofusion or butt welding)			
Part No.	DN	d	K-Factor
TFIV20BE	15	20	193,70
TFIV25BE	20	25	134,07
TFIV32BE	25	32	85,29
TFIV40BE	32	40	48,68
TFIV50BE	40	50	41,68
TFIV20DE	15	20	193,70
TFIV25DE	20	25	134,07
TFIV32DE	25	32	85,29
TFIV40DE	32	40	48,68
TFIV50DE	40	50	41,68

ISO Clamp Saddles for PE SDR 11 pipes			
Part No.	DN	d	K-Factor
SVIC063BME	50	63	27,39
SVIC075BME	65	75	18,75
SVIC090BME	80	90	12,41
SVIC110BME	100	110	7,57
SVIC125BME	110	125	5,76
SVIC140BME	125	140	4,49
SVIC160BME	150	160	3,37
SVIC200BME	180	200	2,02
SVIC225BME	200	225	1,60
SVIC063DME	50	63	27,39
SVIC075DME	65	75	18,75
SVIC090DME	80	90	12,41
SCIC110DME	100	110	7,57
SVIC125DME	110	125	5,76
SVIC140DME	125	140	4,49
SVIC160DME	150	160	3,37
SVIC200DME	180	200	2,02
SVIC225DME	200	225	1,60
SMIC250IME	225	250	1,27
SMIC280IME	250	280	0,99
SMIC315IME	280	315	0,77

## Installation on Metal pipes

316L SS Threaded Tees (BSP Female Threads)			
Part No.	DN	R	K-Factor
TFFX20	15	1/2"	-
TFFX25	20	3/4	157,06
TFFX32	25	1"	92,84
TFFX40	32	1" 1/4	51,52

Metal Strap-on Saddles mounted on Cast Iron pipes		
Part No.	DN	K-Factor
SZIC080I	80	10,22
SZIC100I	100	6,01
SZIC125I	125	3,64
SZIC150I	150	2,46
SZIC200I	200	1,28
SZIC250I	250	0,79
SZIC300I	300	0,53
SZIC350I	350	0,4
SZIC400I	400	0,31
SZIC450I	450	0,24

316L SS Weld-on Adapters mounted on Cast Iron pipes		
Part No.	DN	K-Factor
WAIXL0	40	-
WAIXL0	50	-
WAIXL0	60	19,78
WAIXL0	65	-
WAIXL0	80	10,22
WAIXL0	100	6,01
WAIXL0	110	-
WAIXL0	125	3,64
WAIXL0	150	2,46
WAIXL0	175	-
WAIXL0	200	1,28
WAIXL1	225	-
WAIXL1	250	0,79
WAIXL1	300	0,53
WAIXL1	350	0,40
WAIXL1	400	0,31
WAIXL1	450	0,24
WAIXL1	500	0,20
WAIXL1	600	0,14

Metal Strap-on Saddles mounted on Other Metal pipes		
Part No.	DN	K-Factor
SZIC080I	80	9,61
SZIC100I	100	5,22
SZIC125I	125	3,31
SZIC150I	150	2,22
SZIC200I	200	1,23
SZIC250I	250	0,75
SZIC300I	300	0,52
SZIC350I	350	0,43
SZIC400I	400	0,32
SZIC450I	450	-

316L SS Weld-on Adapters mounted on Other Metal pipes		
Part No.	DN	K-Factor
WAIXL0	40	36,17
WAIXL0	50	23,71
WAIXL0	60	-
WAIXL0	65	13,93
WAIXL0	80	9,61
WAIXL0	100	5,22
WAIXL0	110	-
WAIXL0	125	3,31
WAIXL0	150	2,22
WAIXL0	175	-
WAIXL0	200	1,23
WAIXL1	225	0,75
WAIXL1	250	0,52
WAIXL1	300	0,43
WAIXL1	350	0,32
WAIXL1	400	-
WAIXL1	450	0,20
WAIXL1	500	-
WAIXL1	600	0,14

## Correction formula for K-Factor calculation according to real internal diameter:

$$K\text{-Factor\_NEW} = (K\text{-Factor} \times ID^2) / ID\text{-NEW}^2$$

ID = Value in the table for the internal diameter (in mm)

ID\_NEW = New value for the real internal diameter (always in mm)

K-Factor = Value in the table

K-Factor\_NEW = New K-Factor value for the specified internal diameter

### Example:

Nominal Pipe Size (DN) = 100 mm

New Internal Diameter = 104 mm

Formula:  $K\text{-Factor\_NEW} = (51.02 \times 100^2) / 104^2 = 20,52$

## ORDERING DATA

Part No.	Version	Power supply	Length	Main wetted materials	Enclosure	Flow Rate Range	Weight (gr.)
F3.00.W.13	Hall	See electrical data section	L0	CPVC/EPDM	IP65	0.15 to 8 m/s (0.5 to 25 ft./s.)	750
F3.00.W.14	Hall	See electrical data section	L0	CPVC/FPM	IP65	0.15 to 8 m/s (0.5 to 25 ft./s.)	750
F3.00.W.15	Hall	See electrical data section	L1	CPVC/EPDM	IP65	0.15 to 8 m/s (0.5 to 25 ft./s.)	800
F3.00.W.16	Hall	See electrical data section	L1	CPVC/FPM	IP65	0.15 to 8 m/s (0.5 to 25 ft./s.)	800
F3.00.W.17	Hall	See electrical data section	L0	PVDF/EPDM	IP65	0.15 to 8 m/s (0.5 to 25 ft./s.)	750
F3.00.W.18	Hall	See electrical data section	L0	PVDF/FPM	IP65	0.15 to 8 m/s (0.5 to 25 ft./s.)	750
F3.00.W.19	Hall	See electrical data section	L1	PVDF/EPDM	IP65	0.15 to 8 m/s (0.5 to 25 ft./s.)	800
F3.00.W.20	Hall	See electrical data section	L1	PVDF/FPM	IP65	0.15 to 8 m/s (0.5 to 25 ft./s.)	800
F3.00.W.21	Hall	See electrical data section	L0	316SS/EPDM	IP65	0.15 to 8 m/s (0.5 to 25 ft./s.)	950
F3.00.W.22	Hall	See electrical data section	L0	316SS/FPM	IP65	0.15 to 8 m/s (0.5 to 25 ft./s.)	950
F3.00.W.23	Hall	See electrical data section	L1	316SS/EPDM	IP65	0.15 to 8 m/s (0.5 to 25 ft./s.)	1000
F3.00.W.24	Hall	See electrical data section	L1	316SS/FPM	IP65	0.15 to 8 m/s (0.5 to 25 ft./s.)	1000



**FIP - Formatura Iniezione Polimeri S.p.A.**

Loc. Pian di Parata  
16015 Casella  
Genova - Italy  
Tel. +39 010 96211  
Fax +39 010 9621209  
[www.fisnet.it](http://www.fisnet.it)